

■ SMA ※※ (連座直線軸承)

亞洲泛用公制
ASIA SERIES

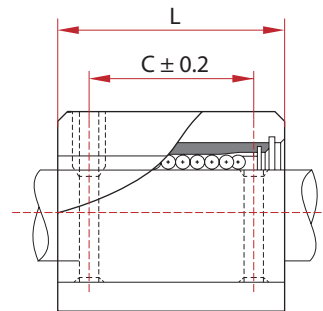
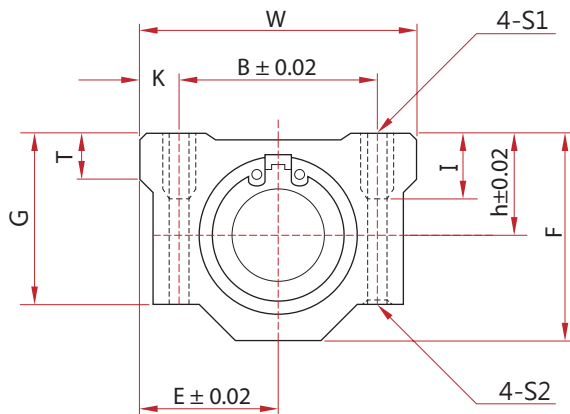

| 型號 MODEL NO | 軸徑 SHAFT DIAMETER | 主要尺寸 MAIN DIMENSIONS | | | | | | | 安裝尺寸 MOUNTING DIMENSIONS | | | | | 動荷重 C(kgf) | 靜荷重 Co(kgf) | 重量 WEIGHT (g) | |
|----------------|-------------------------|----------------------|----|-----|-----|------|------|----|--------------------------|----|------|-----|------|---------------|----------------|---------------------|------|
| | | h | E | W | L | F | G | T | B | C | K | S1 | S2 | | | | I |
| SMA08 | 8 | 11 | 17 | 34 | 30 | 22 | 18 | 6 | 24 | 18 | 5 | M4 | 3.4 | 8 | 28 | 40 | 52 |
| SMA10 | 10 | 13 | 20 | 40 | 35 | 26 | 21 | 8 | 28 | 21 | 6 | M5 | 4.3 | 12 | 38 | 56 | 92 |
| SMA12 | 12 | 15 | 21 | 42 | 36 | 28 | 24 | 8 | 30.5 | 26 | 5.75 | M5 | 4.3 | 12 | 52 | 80 | 102 |
| SMA13 | 13 | 15 | 22 | 44 | 39 | 30 | 24.5 | 8 | 33 | 26 | 5.5 | M5 | 4.3 | 12 | 52 | 80 | 120 |
| SMA16 | 16 | 19 | 25 | 50 | 44 | 38.5 | 32.5 | 9 | 36 | 34 | 7 | M5 | 4.3 | 12 | 79 | 120 | 200 |
| SMA20 | 20 | 21 | 27 | 54 | 50 | 41 | 35 | 11 | 40 | 40 | 7 | M6 | 5.2 | 12 | 90 | 140 | 255 |
| SMA25 | 25 | 26 | 38 | 76 | 67 | 51.5 | 42 | 12 | 54 | 50 | 11 | M8 | 7 | 18 | 100 | 160 | 600 |
| SMA30 | 30 | 30 | 39 | 78 | 72 | 59.5 | 49 | 15 | 58 | 58 | 10 | M8 | 7 | 18 | 160 | 280 | 735 |
| SMA35 | 35 | 34 | 45 | 90 | 80 | 68 | 54 | 18 | 70 | 60 | 10 | M8 | 7 | 18 | 170 | 320 | 1100 |
| SMA40 | 40 | 40 | 51 | 102 | 90 | 78 | 62 | 20 | 80 | 60 | 11 | M10 | 8.7 | 25 | 220 | 410 | 1590 |
| SMA50 | 50 | 50 | 61 | 122 | 110 | 102 | 80 | 25 | 100 | 80 | 11 | M10 | 8.7 | 25 | 390 | 810 | 3340 |
| SMA60 | 60 | 60 | 66 | 132 | 122 | 114 | 94 | 30 | 108 | 90 | 12 | M12 | 10.7 | 25 | 482 | 1020 | 4270 |

■ SMA ※※ L (加長型連座直線軸承)

亞洲泛用公制
ASIA SERIES

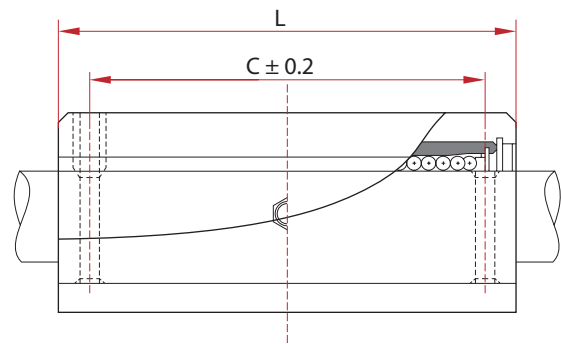
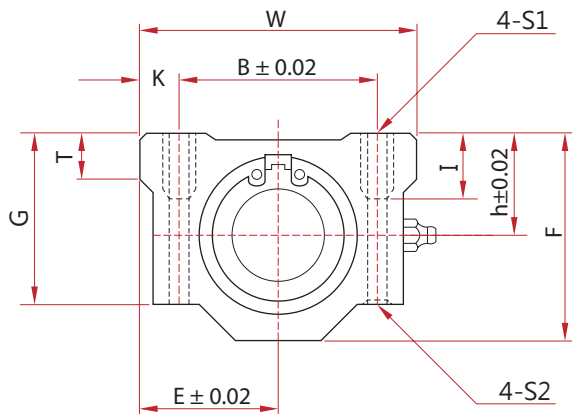

| 型號 MODEL NO | 軸徑 SHAFT DIAMETER | 主要尺寸 MAIN DIMENSIONS | | | | | | | 安裝尺寸 MOUNTING DIMENSIONS | | | | | 動荷重 C(kgf) | 靜荷重 Co(kgf) | 重量 WEIGHT (g) | |
|----------------|-------------------------|----------------------|----|-----|-----|------|------|----|--------------------------|-----|------|-----|------|---------------|----------------|---------------------|------|
| | | h | E | W | L | F | G | T | B | C | K | S1 | S2 | | | | I |
| SMA08L | 8 | 11 | 17 | 34 | 58 | 22 | 18 | 6 | 24 | 42 | 5 | M4 | 3.4 | 8 | 44 | 80 | 102 |
| SMA10L | 10 | 13 | 20 | 40 | 68 | 26 | 21 | 8 | 28 | 46 | 6 | M5 | 4.3 | 12 | 60 | 112 | 180 |
| SMA12L | 12 | 15 | 21 | 42 | 70 | 28 | 24 | 8 | 30.5 | 50 | 5.75 | M5 | 4.3 | 12 | 83 | 160 | 205 |
| SMA13L | 13 | 15 | 22 | 44 | 75 | 30 | 24.5 | 8 | 33 | 50 | 5.5 | M5 | 4.3 | 12 | 83 | 160 | 240 |
| SMA16L | 16 | 19 | 25 | 50 | 85 | 38.5 | 32.5 | 9 | 36 | 60 | 7 | M5 | 4.3 | 12 | 125 | 240 | 400 |
| SMA20L | 20 | 21 | 27 | 54 | 96 | 41 | 35 | 11 | 40 | 70 | 7 | M6 | 5.2 | 12 | 144 | 280 | 570 |
| SMA25L | 25 | 26 | 38 | 76 | 130 | 51.5 | 42 | 12 | 54 | 100 | 11 | M8 | 7 | 18 | 164 | 320 | 1200 |
| SMA30L | 30 | 30 | 39 | 78 | 140 | 59.5 | 49 | 15 | 58 | 110 | 10 | M8 | 7 | 18 | 250 | 560 | 1480 |
| SMA35L | 35 | 34 | 45 | 90 | 155 | 68 | 54 | 18 | 70 | 120 | 10 | M8 | 7 | 18 | 270 | 640 | 2200 |
| SMA40L | 40 | 40 | 51 | 102 | 175 | 78 | 62 | 20 | 80 | 140 | 11 | M10 | 8.7 | 25 | 350 | 820 | 3200 |
| SMA50L | 50 | 50 | 61 | 122 | 215 | 102 | 80 | 25 | 100 | 160 | 11 | M10 | 8.7 | 25 | 620 | 1620 | 6700 |
| SMA60L | 60 | 60 | 66 | 132 | 240 | 114 | 94 | 30 | 108 | 180 | 12 | M12 | 10.7 | 25 | 770 | 2040 | 8560 |

■ SMB ※※ (自潤連座直線軸承)

亞洲泛用公制
ASIA SERIES

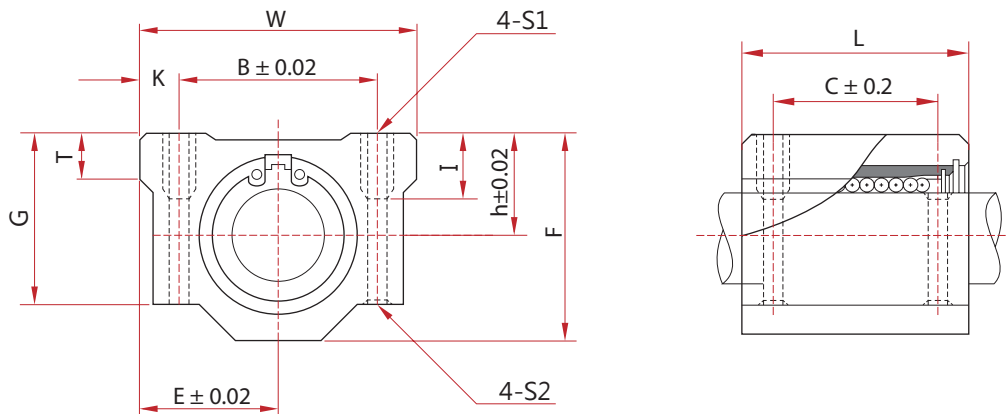

| 型號 MODEL NO | 軸徑 SHAFT DIAMETER | 主要尺寸 MAIN DIMENSIONS | | | | | | | 安裝尺寸 MOUNTING DIMENSIONS | | | | | 動荷重 C(kgf) | 最大速度 m/min | | 重量 WEIGHT (g) | |
|----------------|-------------------------|----------------------|----|-----|-----|------|------|----|--------------------------|----|------|-----|------|---------------|------------|-----|---------------------|------|
| | | h | E | W | L | F | G | T | B | C | K | S1 | S2 | | I | 無給油 | | 給油 |
| SMB08 | 8 | 11 | 17 | 34 | 30 | 22 | 18 | 6 | 24 | 18 | 5 | M4 | 3.4 | 8 | 202 | 40 | 120 | 45 |
| SMB10 | 10 | 13 | 20 | 40 | 35 | 26 | 21 | 8 | 28 | 21 | 6 | M5 | 4.3 | 12 | 305 | 40 | 120 | 78 |
| SMB12 | 12 | 15 | 21 | 42 | 36 | 28 | 24 | 8 | 30.5 | 26 | 5.75 | M5 | 4.3 | 12 | 378 | 40 | 120 | 89 |
| SMB16 | 16 | 19 | 25 | 50 | 44 | 38.5 | 32.5 | 9 | 36 | 34 | 7 | M5 | 4.3 | 12 | 622 | 40 | 120 | 170 |
| SMB20 | 20 | 21 | 27 | 54 | 50 | 41 | 35 | 11 | 40 | 40 | 7 | M6 | 5.2 | 12 | 882 | 40 | 120 | 220 |
| SMB25 | 25 | 26 | 38 | 76 | 67 | 51.5 | 42 | 12 | 54 | 50 | 11 | M8 | 7 | 18 | 1549 | 40 | 120 | 500 |
| SMB30 | 30 | 30 | 39 | 78 | 72 | 59.5 | 49 | 15 | 58 | 58 | 10 | M8 | 7 | 18 | 2016 | 40 | 120 | 635 |
| SMB35 | 35 | 34 | 45 | 90 | 80 | 68 | 54 | 18 | 70 | 60 | 10 | M8 | 7 | 18 | 2573 | 40 | 120 | 925 |
| SMB40 | 40 | 40 | 51 | 102 | 90 | 78 | 62 | 20 | 80 | 60 | 11 | M10 | 8.7 | 25 | 3360 | 40 | 120 | 1340 |
| SMB50 | 50 | 50 | 61 | 122 | 110 | 102 | 80 | 25 | 100 | 80 | 11 | M10 | 8.7 | 25 | 5250 | 40 | 120 | 2590 |
| SMB60 | 60 | 60 | 66 | 132 | 122 | 114 | 94 | 30 | 108 | 90 | 12 | M12 | 10.7 | 25 | 6930 | 40 | 120 | 3430 |

■ SMB ※※ L (加長型自潤連座直線軸承)

亞洲泛用公制
ASIA SERIES

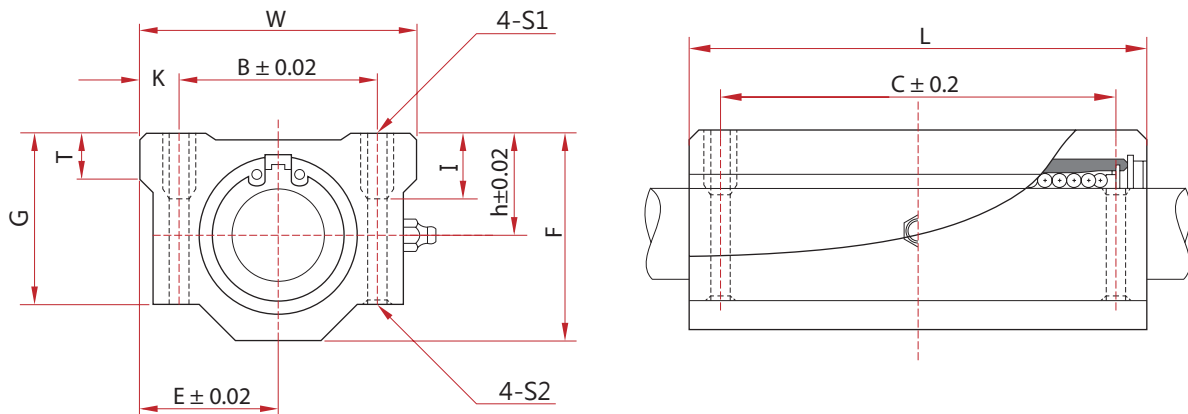

| 型號 MODEL NO | 軸徑 SHAFT DIAMETER | 主要尺寸 MAIN DIMENSIONS | | | | | | | 安裝尺寸 MOUNTING DIMENSIONS | | | | | 動荷重 C(kgf) | 最大速度 m/min | | 重量 WEIGHT (g) | |
|----------------|-------------------------|----------------------|----|-----|-----|------|------|----|--------------------------|-----|------|-----|------|---------------|------------|-----|---------------------|------|
| | | h | E | W | L | F | G | T | B | C | K | S1 | S2 | | I | 無給油 | | 給油 |
| SMB08L | 8 | 11 | 17 | 34 | 58 | 22 | 18 | 6 | 24 | 42 | 5 | M4 | 3.4 | 8 | 400 | 40 | 120 | 90 |
| SMB10L | 10 | 13 | 20 | 40 | 68 | 26 | 21 | 8 | 28 | 46 | 6 | M5 | 4.3 | 12 | 700 | 40 | 120 | 150 |
| SMB12L | 12 | 15 | 21 | 42 | 70 | 28 | 24 | 8 | 30.5 | 50 | 5.75 | M5 | 4.3 | 12 | 750 | 40 | 120 | 180 |
| SMB16L | 16 | 19 | 25 | 50 | 85 | 38.5 | 32.5 | 9 | 36 | 60 | 7 | M5 | 4.3 | 12 | 1200 | 40 | 120 | 340 |
| SMB20L | 20 | 21 | 27 | 54 | 96 | 41 | 35 | 11 | 40 | 70 | 7 | M6 | 5.2 | 12 | 1700 | 40 | 120 | 500 |
| SMB25L | 25 | 26 | 38 | 76 | 130 | 51.5 | 42 | 12 | 54 | 100 | 11 | M8 | 7 | 18 | 3000 | 40 | 120 | 1000 |
| SMB30L | 30 | 30 | 39 | 78 | 140 | 59.5 | 49 | 15 | 58 | 110 | 10 | M8 | 7 | 18 | 4000 | 40 | 120 | 1280 |
| SMB35L | 35 | 34 | 45 | 90 | 155 | 68 | 54 | 18 | 70 | 120 | 10 | M8 | 7 | 18 | 5100 | 40 | 120 | 1850 |
| SMB40L | 40 | 40 | 51 | 102 | 175 | 78 | 62 | 20 | 80 | 140 | 11 | M10 | 8.7 | 25 | 6700 | 40 | 120 | 2700 |
| SMB50L | 50 | 50 | 61 | 122 | 215 | 102 | 80 | 25 | 100 | 160 | 11 | M10 | 8.7 | 25 | 10500 | 40 | 120 | 5200 |
| SMB60L | 60 | 60 | 66 | 132 | 240 | 114 | 94 | 30 | 108 | 180 | 12 | M12 | 10.7 | 25 | 13800 | 40 | 120 | 6900 |

■ SME ※※ (連座直線軸承)

亞洲泛用公制
ASIA SERIES

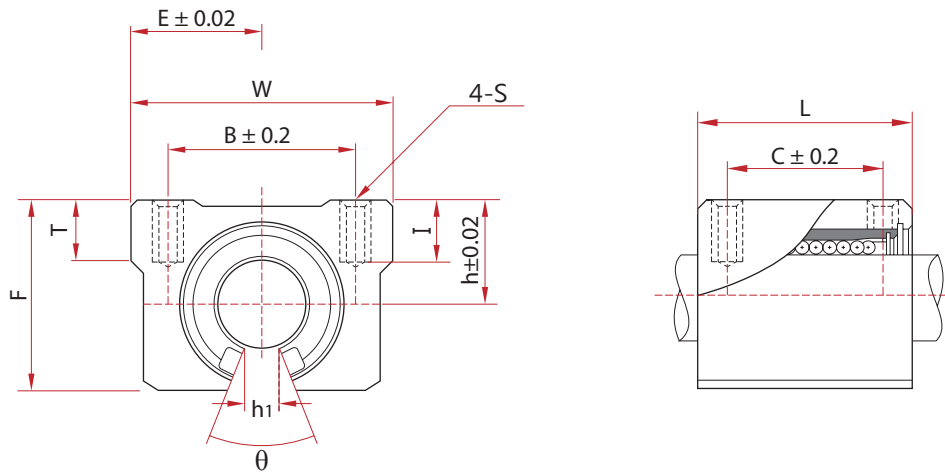

| 型號 MODEL NO | 軸徑 SHAFT DIAMETER | 主要尺寸 MAIN DIMENSIONS | | | | | | | | 安裝尺寸 MOUNTING DIMENSIONS | | | | 動荷重 C(kgf) | 靜荷重 Co(kgf) | 重量 WEIGHT (g) |
|----------------|-------------------------|----------------------|------|-----|-----|------|----|------|-----|--------------------------|----|-----|----|---------------|----------------|---------------------|
| | | H | E | W | L | F | T | h1 | θ | B | C | S | I | | | |
| SME10 | 10 | 15 | 18 | 36 | 32 | 24 | 7 | 6 | 80° | 25 | 20 | M5 | 10 | 38 | 56 | 92 |
| SME12 | 12 | 17 | 20 | 40 | 39 | 27.6 | 8 | 8.5 | 80° | 28 | 26 | M5 | 10 | 52 | 80 | 102 |
| SME13 | 13 | 17 | 20 | 40 | 39 | 27.6 | 8 | 8.5 | 80° | 28 | 26 | M5 | 10 | 52 | 80 | 120 |
| SME16 | 16 | 20 | 22.5 | 45 | 45 | 33 | 9 | 10 | 80° | 32 | 30 | M5 | 12 | 79 | 120 | 200 |
| SME20 | 20 | 23 | 24 | 48 | 50 | 39 | 11 | 10 | 60° | 35 | 35 | M6 | 12 | 90 | 140 | 255 |
| SME25 | 25 | 27 | 30 | 60 | 65 | 47 | 14 | 11.5 | 50° | 40 | 40 | M8 | 12 | 100 | 160 | 600 |
| SME30 | 30 | 33 | 35 | 70 | 70 | 56 | 15 | 14 | 50° | 50 | 50 | M8 | 18 | 160 | 280 | 735 |
| SME35 | 35 | 37 | 40 | 80 | 80 | 63 | 18 | 16 | 50° | 55 | 55 | M8 | 18 | 170 | 320 | 1100 |
| SME40 | 40 | 42 | 45 | 90 | 90 | 72 | 20 | 19 | 50° | 65 | 65 | M10 | 20 | 220 | 410 | 1590 |
| SME50 | 50 | 53 | 60 | 120 | 110 | 92 | 25 | 23 | 50° | 94 | 80 | M10 | 20 | 390 | 810 | 3340 |

■ SME ※※ L (連座直線軸承)

亞洲泛用公制
ASIA SERIES

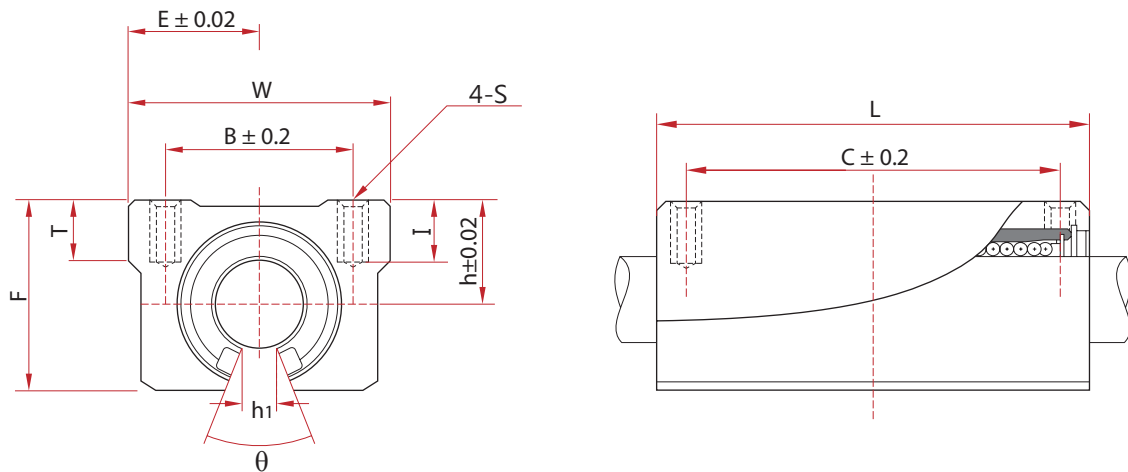

| 型號 MODEL NO | 軸徑 SHAFT DIAMETER | 主要尺寸 MAIN DIMENSIONS | | | | | | | | 安裝尺寸 MOUNTING DIMENSIONS | | | | 動荷重 C(kgf) | 靜荷重 Co(kgf) | 重量 WEIGHT (g) |
|----------------|-------------------------|----------------------|------|----|-----|----|----|------|-----|--------------------------|-----|-----|----|---------------|----------------|---------------------|
| | | H | E | W | L | F | T | h1 | θ | B | C | S | I | | | |
| SME16 | 16 | 20 | 22.5 | 45 | 85 | 33 | 9 | 10 | 80° | 32 | 60 | M5 | 12 | - | - | 200 |
| SME20 | 20 | 23 | 24 | 48 | 96 | 39 | 11 | 10 | 80° | 35 | 70 | M6 | 12 | - | - | 255 |
| SME25 | 25 | 27 | 30 | 60 | 130 | 47 | 14 | 11.5 | 80° | 40 | 100 | M6 | 12 | - | - | 600 |
| SME30 | 30 | 33 | 35 | 70 | 140 | 56 | 15 | 14 | 80° | 50 | 110 | M8 | 18 | - | - | 735 |
| SME40 | 40 | 42 | 45 | 90 | 175 | 72 | 20 | 19 | 80° | 65 | 140 | M10 | 20 | - | - | 1590 |